

DATA SHEET

6 Channel Solid State Relay Board 3034 Series

DESCRIPTION

The 3034 Series is a six channel relay board series with a choice of supply voltages and relay driving methods

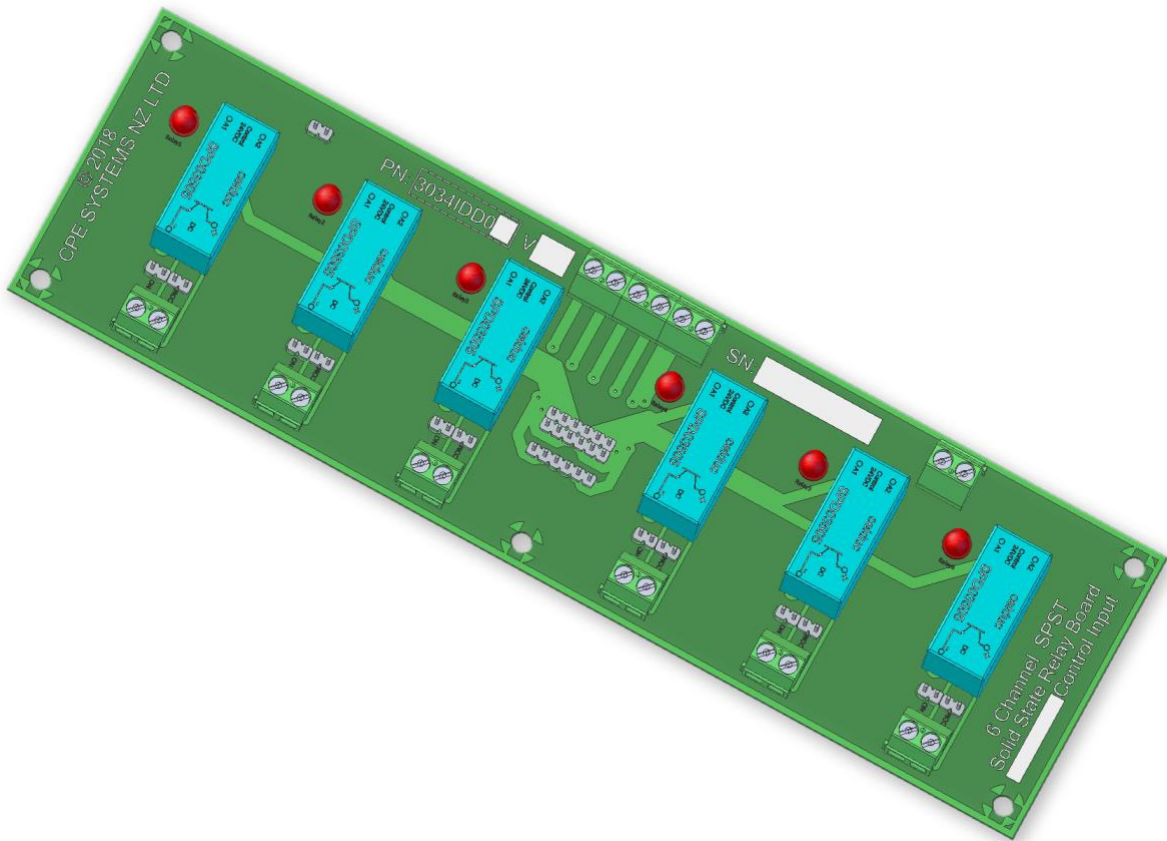

Document ID: 3034OPM002

Date: 04/01/2018

Version: 0-0

General Specifications

Mechanical		
Board Length	230mm	
Board Width	65mm	
Board Height	30.6mm	
Mounting Holes	5 @ 4.1mm Dia.	
PCB Thickness	1.6mm	
PCB Material	FR-4	
Electrical		
Screw Terminal Conductor	Tin	
PCB Header Conductor	Tin Coated Brass	
Relay Contact Arrangement	1 form A (1 NO)	
Relay Type	Solid State	
Relay Control Type	DC Non-Polarized Optocoupler	
Relay Switching Ratings	Maximum Peak Rated Power	600W
	Maximum Peak Voltage	60V
	Maximum Constant Current	5A
	Non-Repetitive Peak Overload Current	25A
	ON state Voltage Drop Across Relay	0.3V
	On State Static Output Resistance	60mΩ
	Minimum Load Current	1mA
	Operate Time Max	50μs
	Release Time Max	600μs
	Max Switching Frequency	100Hz
Ambient Temperature	-40°C to +100°C	

Series Specifications

Order Code	3034IDD011	
Description Code (Refer Key in Page 5)	24-SS-SPNO-06-D	
Board Voltage Input	24V	
Max. Board Power Required @ 24V All Channels ON	3.73 W	
Leakage Current (All Channels Off)	Leakage Current of Driving Device *6 Channels OR <1mA per Channel. <i>Whichever is Smallest</i> *6 Channels	
Require Min. Driving Current per Channel @ Rated Input Voltage (24V)	18.7mA (Sinking)	
Relay Optocoupler Drive	Nominal Voltage	24V
	Operate Voltage	10V - 30V
	Release Voltage	2.5V
	Nominal Current	9.3mA
	Operate Current	4mA - 12mA
	Resistance	2100 ohms
	Nominal Power	270mW
	Rated Power	420mW

Order Code	3034IDD012	
Description Code (Refer Key in Page 5)	24-SS-SPNO-06-T	
Board Voltage Input	24V	
Max. Board Power Required @ 24V All Channels ON	3.41 W	
Leakage Current (All Channels Off)	500µA per Channel 4mA Total (8 Channel Driver)	
Require Min. Driving Current per Channel @ Rated Coil Input Voltage (24V)	18.2mA (Sinking)	
TTL Driving Signal Requirements	$I_{ON} = 1mA$	
	$V_I = 3.85V$	
Relay Optocoupler Drive	Nominal Voltage	24V
	Operate Voltage	10V - 30V
	Release Voltage	2.5V
	Nominal Current	9.3mA
	Operate Current	4mA - 12mA
	Resistance	2100 ohms
	Nominal Power	270mW
	Rated Power	420mW

Relay Boards Description Code Key

CODE	Relay Control Voltage	Relay Type	Relay Configuration	Number of Relays per board	Relay Control Signal Type	Additional Options
5 V	05					
12 V	12					
24 V	24					
Mechanical	ME					
Solid State	SS					
Low Voltage Reed	LR					
High Voltage Reed	HR					
Single Pole Single Throw - Normally Closed	SPNC					
Single Pole Single Throw - Normally Open	SPNO					
Single Pole Double Throw	SPDT					
Double Pole Single Throw - Normally Closed	DPNC					
Double Pole Single Throw - Normally Open	DPNO					
Double Pole Double Throw	DPDT					
6 Relays	06					
8 Relays	08					
TTL / DIO Controlled	T					
Relay Driver Controlled	D					
None						
Conformal Coated	CC					
Custom Modifications / Features (On Order)	CM					

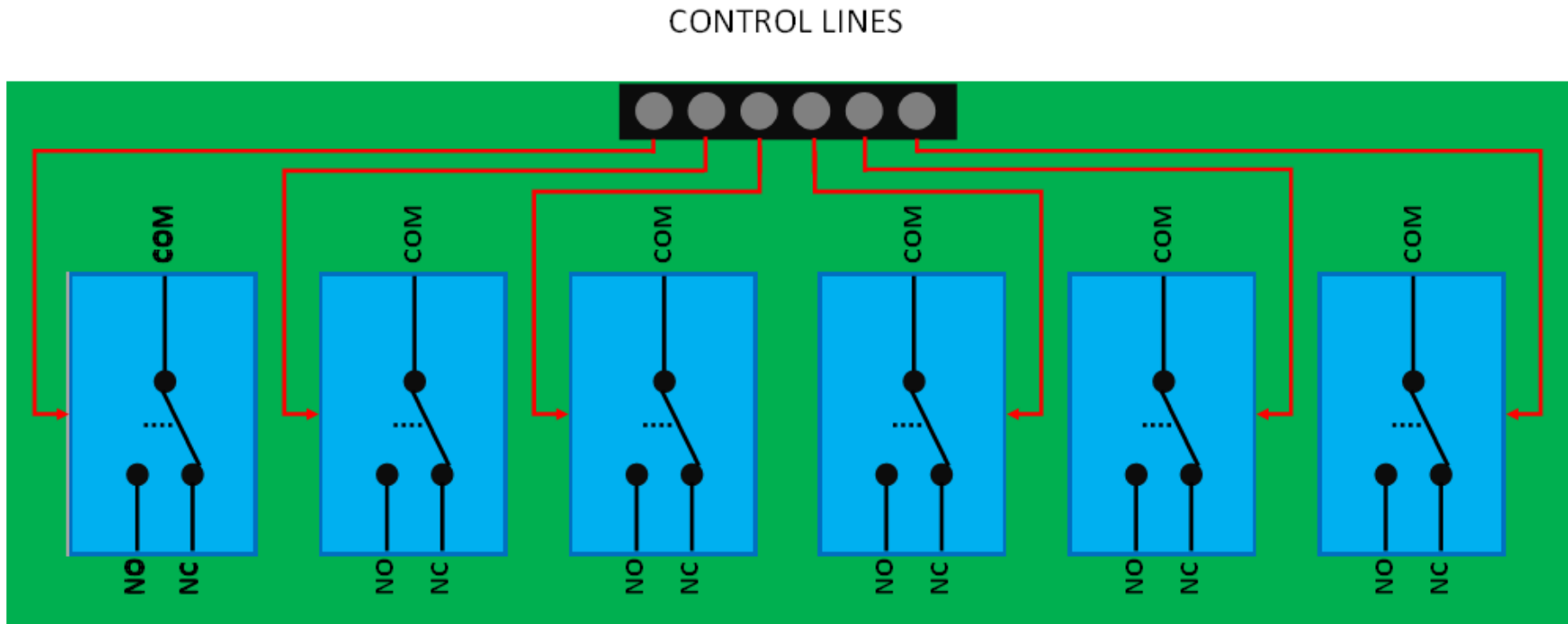

Figure 1 - Block Diagram of SS Relay Board Functionality